

Downlight

QCan Suspension Bracket

CODE: QCAN-120-SB/BK

QVIS[®]
LIGHTING & SECURITY

Dimensions

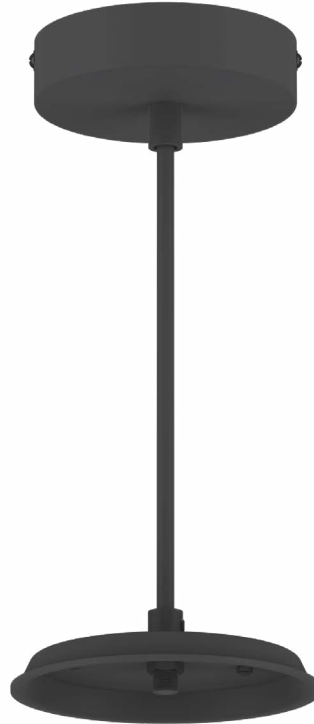
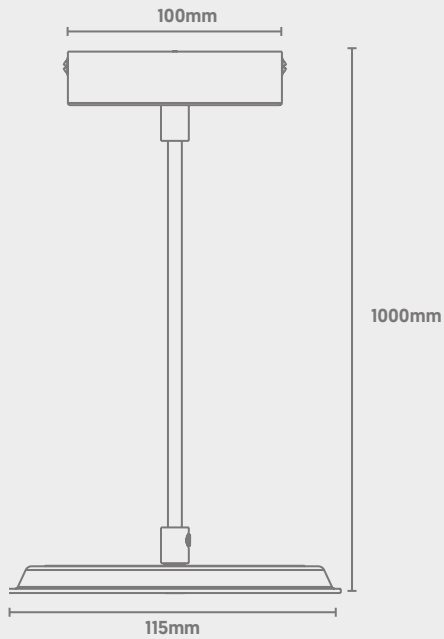

Technical

Dimensions

1000mm x115mm x100mm