

# Continuous Linear



Various Mounting Options



Wattage Switchable



1-10V Dimmable (as Standard)



Tri-Colour (3000K/4000K/5000K)

## Dimensions

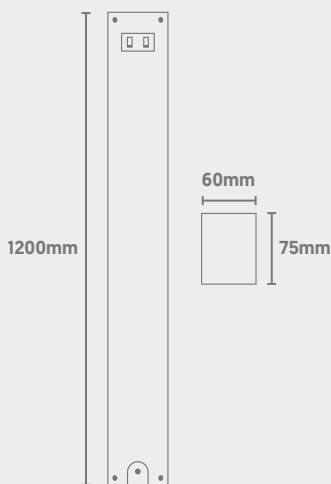

Light Source Energy Rating

## Photometric Data

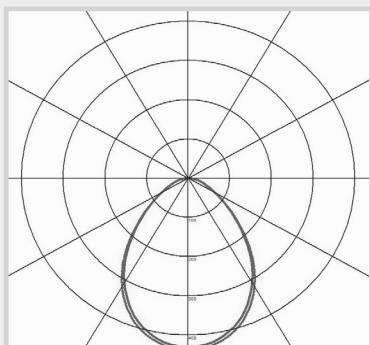

# SpecLine

## Direct Linear

QVIS®

LIGHTING & SECURITY

CODE: SPECLINE-WS-1200TC

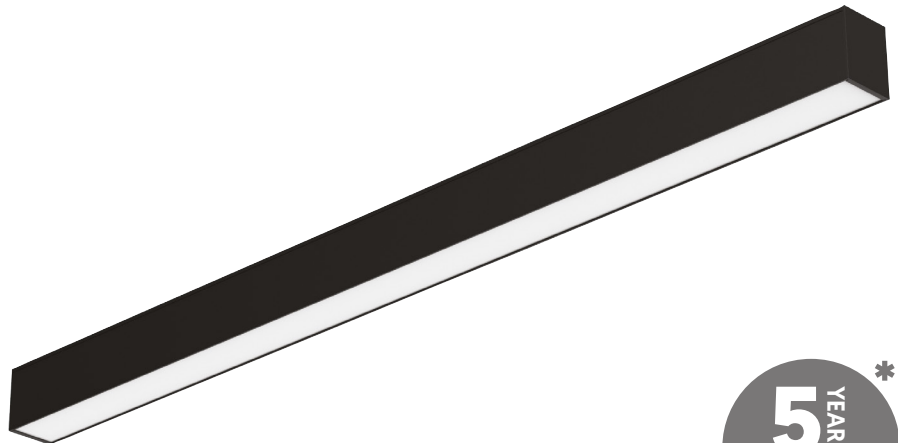

Power (Selectable)	Efficacy	Output	Kelvin
24W	120Lm/cW	2880Lm	Tri-Colour: 3000K, 4000K or 5000K
32W	120Lm/cW	3840Lm	
40W	120Lm/cW	4800Lm	

## Technical

Input Voltage	AC 200-240V
Colour Rendering Index	>80
Beam Spread	90°
Diffuser Type	Microprismatic
Operating Temp.	-20 to +45°C
Materials	Aluminium & Polycarbonate
IP Rating	IP20
Dimmable	1-10V (as Standard)
Dimensions	1200mm x 75mm x 60mm
Weight	2.4kg
MacAdam Step	<3
Lifetime	50,000 hours, L70-B10 (Ta 25 °C)
CE Standards	EN60598-1, EN62493, EN55015, EN61547, EN61000-3-2, EN61000-3-3, EN62722-1, EN62722-2-1 and EN50581
CE Directives	LVD, EMC, ERP & RoHS