

Downlight



IP44 Ingress Protection



TP(b) Fire Rating



Slim Design Profile (12mm)



Edge-Lit Luminaire

Dimensions

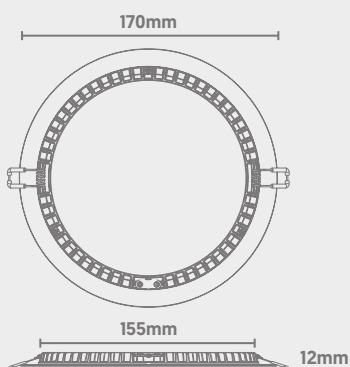

Light Source Energy Rating

Photometric Data

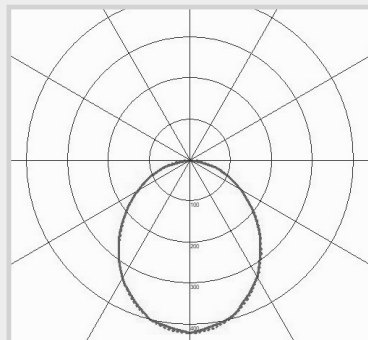

QDisc

Slimline Recessed Downlight

QVIS[®]

LIGHTING & SECURITY

CODE: QDISC-12-170NW



Power	Efficacy	Output	Kelvin
12W	105Lm/cW	1260Lm	4000K

Technical

Input Voltage	AC 200-240V
Beam Spread	120°
Diffuser Type	Opal
Operating Temp.	-20 to +45°C
Materials	Aluminium & Polycarbonate
IP Rating	IP44
Fire Rating	TP(b)
Dimmable	On Request
Cut Out	155mm
Dimensions	170mm x 12mm
Weight	0.3kg
MacAdam Step	<3
Lifetime	50,000 hours, L70-B10 (Ta 25 °C)
CE Standards	EN60598-1, EN 60598 2-2, EN62493, EN55015, EN61547, EN61000-3-2, EN61000-3-3, EN62722-1, EN62722-2-1 and EN50581
CE Directives	LVD, EMC, ERP & RoHS