

Downlight



IP67 Ingress Protection



TP(a) Fire Rating



Back-Lit Luminaire



Aluminium Housing

Dimensions

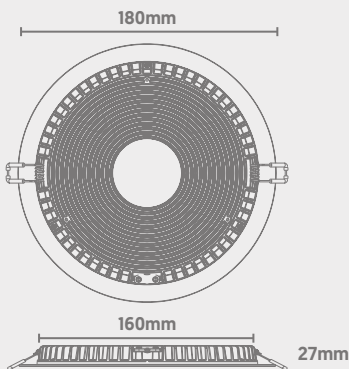

Photometric Data

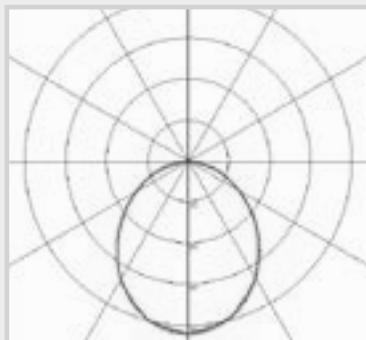

Helios

IP65 Recessed Downlight

QVIS[®]

LIGHTING & SECURITY

CODE: H65-PRO-WS-180TC/LG/EM



Power	Efficacy	Output	Kelvin
10W [Emergency 3W]	150Lm/cW	1500Lm [Emergency 450Lm]	Tri-Colour: 3000K, 4000K & 6000K
12W [Emergency 3W]	150Lm/cW	1800Lm [Emergency 450Lm]	
15W [Emergency 3W]	150Lm/cW	2250Lm [Emergency 450Lm]	
17W [Emergency 3W]	150Lm/cW	2550Lm [Emergency 450Lm]	

Technical

Input Voltage	AC 200-240V
Colour Rendering Index	>85
Beam Spread	90°
Diffuser Type	Low Glare
Power Factor	>0.9
Operating Temp.	-20 to +65°C
Materials	Aluminium & Polycarbonate
IP Rating	IP67
Fire Rating	TP(a)
Dimmable	On Request
Cut Out	160mm
Dimensions	180mm x 27mm
Weight	0.705kg
MacAdam Step	<3
Emergency Output	3 Hours [3W]
Lifetime	50,000 hours, L90-B10 (Ta 25 °C)
CE Standards	EN60598-1, EN 60598 2-2, EN62493, EN55015, EN61547, EN61000-3-2, EN61000-3-3, EN62722-1, EN62722-2-1 and EN50581
CE Directives	LVD, EMC, ERP & RoHS