

# Modular



IP44 Ingress Protection



TP(a) Fire Rating



Wattage Switchable



Low Glare Diffuser

## Dimensions

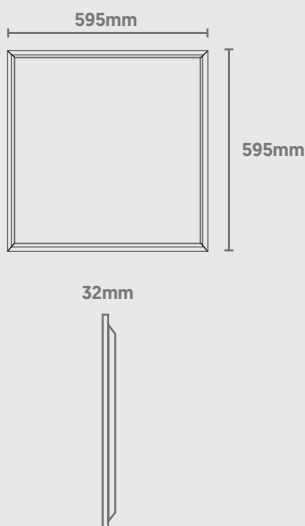

## Photometric Data

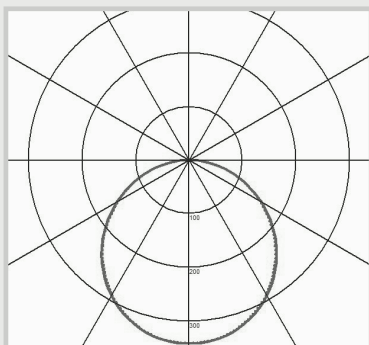

# ON-X TP(a) Backlit Panel

CODE: OX-TPA-WS2-6X6NW/LG

**QVIS**<sup>®</sup>  
LIGHTING & SECURITY



Power (Selectable)	Efficacy	Output	Kelvin
26W	120Lm/cW	3120Lm	4000K
30W	120Lm/cW	3600Lm	
38W	120Lm/cW	4560Lm	

## Technical

Input Voltage	AC 200-240V
Colour Rendering Index	>85
Beam Spread	160°
Diffuser Type	Microprismatic
Power Factor	>0.95
Typical UGR	<19
Operating Temp.	-20 to +50°C
Materials	Aluminium
IP Rating	IP44
Fire Rating	TP(a)
Dimmable	On Request
Dimensions	595mm x 595mm x 32mm
Weight	2.5kg
MacAdam Step	<3
Lifetime	50,000 hours, L70-B10 (Ta 25 °C)
CE Standards	EN60598-1, EN 60598 2-2, EN62493, EN55015, EN61547, EN61000-3-2, EN61000-3-3, EN62722-1, EN62722-2-1 and EN50581
CE Directives	LVD, EMC, ERP & RoHS