

Modular



IP44 Ingress Protection



TP(a) Fire Rating



Wattage Switchable



Low Glare Diffuser

Dimensions

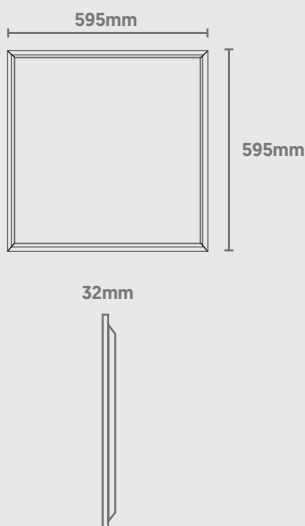

Photometric Data

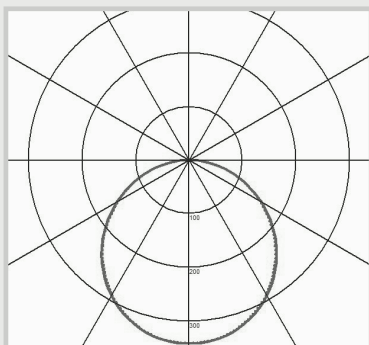

ON-X TP(a) Backlit Panel

CODE: OX-TPA-WS-6X6NW/LG/EM

QVIS[®]
LIGHTING & SECURITY



Power (Selectable)	Efficacy	Output	Kelvin
26W [Emergency 3W]	120Lm/cW	3120Lm [Emergency 360Lm]	4000K
30W [Emergency 3W]	120Lm/cW	3600Lm [Emergency 360Lm]	
38W [Emergency 3W]	120Lm/cW	4560Lm [Emergency 360Lm]	

Technical

Input Voltage	AC 200-240V
Colour Rendering Index	>85
Beam Spread	160°
Diffuser Type	Microprismatic
Power Factor	>0.95
Typical UGR	<19
Operating Temp.	-20 to +50°C
Materials	Aluminium
IP Rating	IP44
Fire Rating	TP(a)
Dimmable	On Request
Dimensions	595mm x 595mm x 32mm
Weight	2.705kg
MacAdam Step	<3
Emergency	3 Hours [3W]
Lifetime	50,000 hours, L70-B10 (Ta 25 °C)
CE Standards	EN60598-1, EN 60598 2-2, EN62493, EN55015, EN61547, EN61000-3-2, EN61000-3-3, EN62722-1, EN62722-2-1 and EN50581
CE Directives	LVD, EMC, ERP & RoHS