

Continuous Linear



Various Mounting Options



Wattage Switchable



1-10 Dimmable (As Standard)



Tri-Colour (3000K/4000K/5000K)

Dimensions

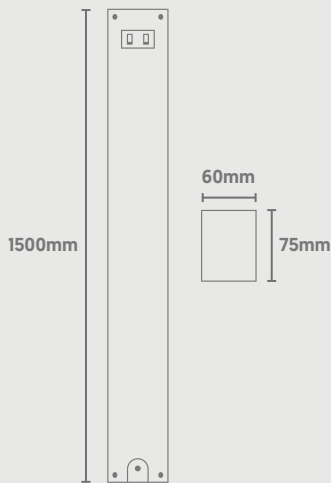

SpecLine

Direct Linear

QVIS[®]

LIGHTING & SECURITY

CODE: SPECLINE-WS-1500TC/ID



Power (Selectable)	Efficacy	Output	Kelvin
36W	120Lm/cW	4320Lm	Tri-Colour: 3000K, 4000K or 5000K
48W	120Lm/cW	5760Lm	
60W	120Lm/cW	7200Lm	

Technical

Input Voltage	AC 200-240V
Colour Rendering Index	>80
Beam Spread	110°
Diffuser Type	Microprismatic
Operating Temp.	-20 to +45°C
Materials	Aluminium & Polycarbonate
IP Rating	IP20
Dimmable	1-10 Dimmable
Dimensions	1500mm x 75mm x 60mm
Weight	3kg
MacAdam Step	<3
Lifetime	50,000 hours, L70-B10 (Ta 25 °C)
CE Standards	EN60598-1, EN62493, EN55015, EN61547, EN61000-3-2, EN61000-3-3, EN62722-1, EN62722-2-1 and EN50581
CE Directives	LVD, EMC, ERP & RoHS

Photometric Data

