

Surface & Suspended

Ikon S Wall Mounted Luminaire

CODE: IKON-S-1200X260NW



Direct/Indirect Output



UGR Compliant Diffuser



Aluminium Housing

Dimensions

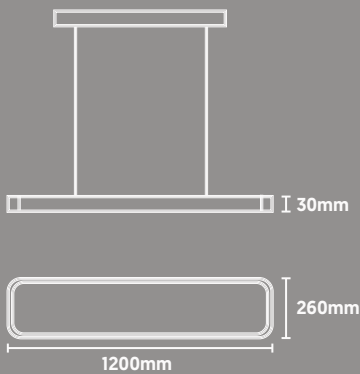

DECORATIVE RANGE

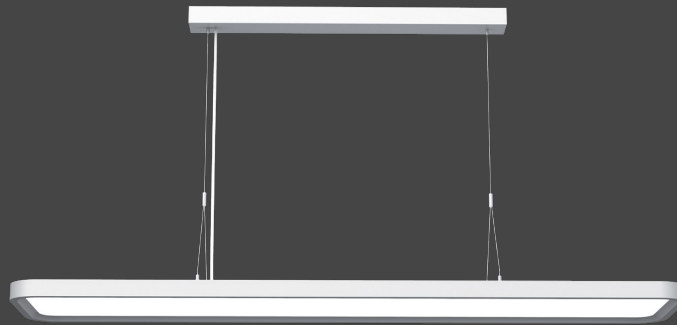

Power	Efficacy	Output	Kelvin
60W	105Lm/cW	2100Lm ↑ 4200Lm ↓	4000K

Technical

Input Voltage	AC 100-270V
Direct/Indirect	30% ↑ / 70% ↓
Colour Rendering Index	>80
Power Factor	>0.9
Operating Temp.	-20 to +45°C
Materials	Aluminium & Polycarbonate
IP Rating	IP20
Dimmable	On Request
Dimensions	1200mm x 260mm x 30mm
Weight	6.37kg
MacAdam Step	<3
Lifetime	50,000 hours, L90-B10 (Ta 25 °C)
CE Standards	EN60598-1, EN62493, EN55015, EN61547, EN61000-3-2, EN61000-3-3, EN62722-1, EN62722-2-1 and EN50581
CE Directives	LVD, EMC, ERP & RoHS

A T G F Light Source Energy Rating

Photometric Data

