

GLOWCLEAN HIGHBAY

GLOWCLEAN-50NW

QVIS[®]

LIGHTING & SECURITY

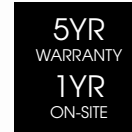

Driver as Standard



LED's inside

TECHNICAL DRAWINGS

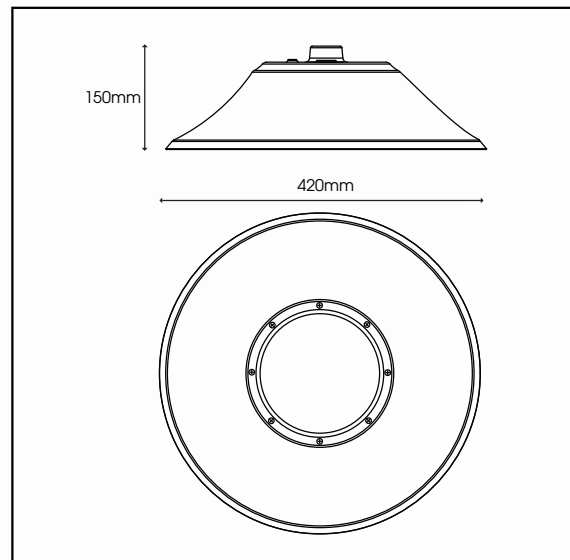

LUMINOUS INTENSITY DISTRIBUTION DIAGRAM

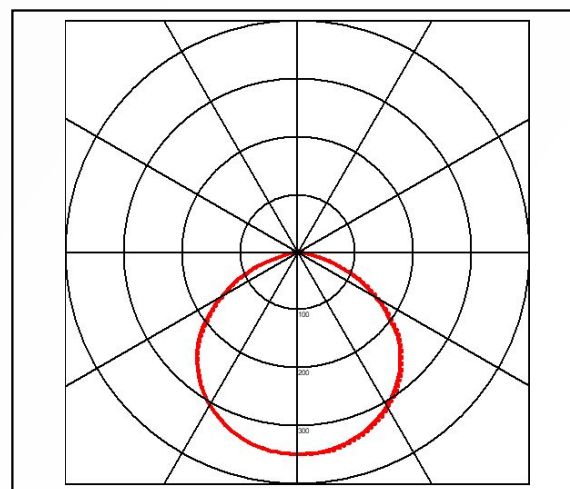

Specification	Glowclean 50W
System Power	50W
LED Chipset	Samsung
Driver Manufacturer	Lifud
Colour Rendering Index	>80
Lumen Output	7500Lm
LED Efficacy	150 Lm/cW
Power Factor	>0.9
IP Rating	IP65
IK Rating	IK10
Beam Spread	120 °
Colour Temperature	4000K
Housing Material	Aluminium
Diffuser Type	Polycarbonate
Operating Temperature	-30 to 50 °C
Input Voltage	AC 100-240V
Weight	5kg
Dimensions	∅420mm x 150mm
MacAdam Step	<3
Lifetime	50,000 hours, L70-B10 (Ta 25 °C)
CE Standards	EN60598-1, EN 60598 2-5, EN62493, EN55015, EN61547, EN61000-3-2, EN61000-3-3, EN62722-1, EN62722-2-1 and EN50581
CE Directives	LVD, EMC, ERP & RoHS

* Warranty terms and conditions apply

INDUSTRIAL RANGE