

# Surface Mount Kits

MOUNTING KITS - 6X6 - 12X3 - 12X6

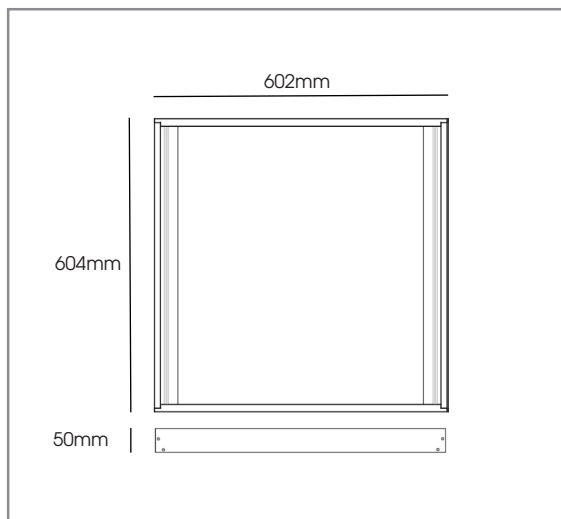

## 6x6 Surface Mount Kit

- Powder Coated Aluminium
- Assembly Needed
- Dimensions: 604mm x 602mm x 50mm
- Weight: 1.15kg

Order Code:

SMFT - 600X600

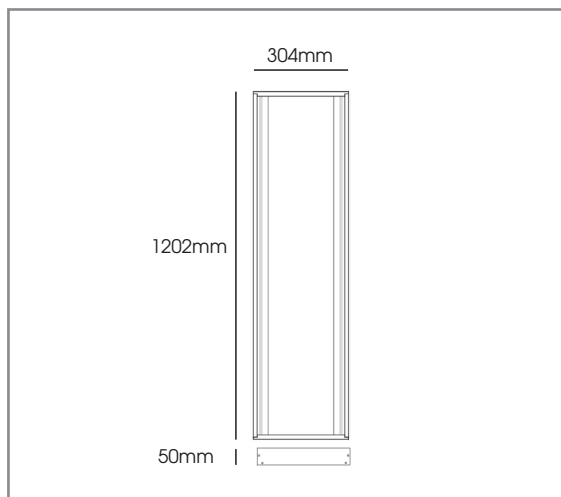

## 12x3 Surface Mount Kit

- Powder Coated Aluminium
- Assembly Needed
- Dimensions: 1202mm x 304mm x 50mm
- Weight: 1.85kg

Order Code:

SMFT - 1200X300

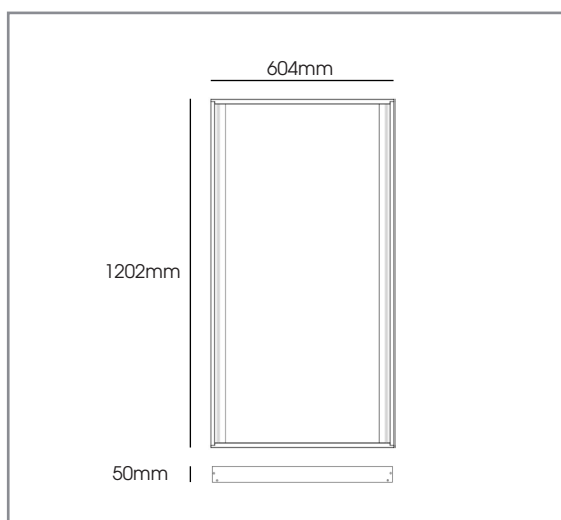

## 12x6 Surface Mount Kit

- Powder Coated Aluminium
- Assembly Needed
- Dimensions: 1202mm x 604mm x 50mm
- Weight: 2kg

Order Code:

SMFT - 1200X600

# QVIS

## LIGHTING

Qvis Lighting has specialised in commercial and industrial LED lighting since 2014, whilst the Qvis brand itself has been established for over ten years, with track record success in many industries. From the outset, Qvis has signed up to the Lighting Industrial Association (LIA) and is actively part of their Quality Assurance program (LIAQA). Similarly, Qvis is part of the Philips enabled licensing community, the manufacturers association (EEF), ICEL emergency association, and an ISO 9001:2015 quality management firm.

Qvis products are fully tested by the LIA independent testing laboratories and have gained membership to the Carbon Trust and the Society of Light and Lighting. Qvis continues to win accolades within the industry, with recognition as an LED supplier with quick high quality bespoke product turnarounds and cutting-edge efficacy across the range. Using the latest LED technology advancements, the Qvis brand is now very much established as an affordable name without compromising on quality or performance.

Using only high-end components and LED chips from global manufacturers worldwide, long life and serviceability on all its lighting products is standard practice. Focusing on energy efficiency and performance, the range of fully integrated LED luminaires- suitable for the commercial, health, industrial, retail and education sectors. With 1-10V, Switch Dim and DALI options, Qvis offer dimmable solutions for lighting control requirements, assisting in energy saving and the reduction of carbon footprint.

To further enhance its growing reputation and brand recognition within the UK, Qvis has acquired lighting specialists from some of the biggest manufacturers in Europe. Using their wealth of knowledge and expertise in design, supply and implementation. Qvis, under the Adata umbrella, will continue to invest in their people and technology and are committed to providing the industry with result driven solutions.

### Accreditation



The Society of  
Light and Lighting



LIA  
Laboratories



### Component Suppliers Include:

**PHILIPS**

**CITIZEN**

**TRIDONIC**  
enlightening your ideas



**LIFUD**

**EPISTAR**

**NICHIA**

**CREE**

**Harvard**  
Technology



**QVIS**  
LED LIGHTING  
Affordability Without Compromise

For further information on our products or terms and conditions visit our website [www.qvisled.com](http://www.qvisled.com) email: [sales@qvislighting.com](mailto:sales@qvislighting.com) or phone: 023 9387

Disclaimer: Please note, all information and images are subject to change without prior notice.